

Save Water and Money

- No filter media to clean or replace
- Cuts backwashing
- Reduces filter maintenance
- Suitable for both new and existing installations
- 2 year warranty

MultiCyclone is the brilliant new pre-filtration device that can help you save 7000 litres of water a year in an average pool and reduce filter maintenance.

Based on the principals of centrifugal water filtration – MultiCyclone collects 80% of the dirt that clogs your filter before it gets there.

It drastically reduces backwashing and filter cartridge maintenance – yet it only takes 15 litres of water to flush MultiCyclone, saving you water and money.



2007
Piscina Barcelona
Sustainability Award

MultiCyclone is a pre-filtration device that is capable of saving water and reducing filter maintenance.

The MultiCyclone works on the basis of centrifugal water filtration. There are no moving parts to wear and tear, and no filter media to clean or replace.

MultiCyclone extends the life of your filter and cuts water consumption as it eases the workload on your swimming pool filter.



Centrifugal filtration

- i. Incoming water enters 16 hydro cyclones tangentially, generating a strong centrifugal effect.
- ii. The sediment is spun out to the hydro cyclone's wall, and then spirals down to the sediment chamber.
- iii. The filtered water migrates towards the center of the hydro cyclone where the flow reverses and spirals upwards through the outlet.
- iv. Accumulation of sediment can be visibly monitored through the MultiCyclone's clear sediment chamber.
- v. The MultiCyclone is easily cleaned by opening the valve. Only 15 litres of water is discharged to cleanse the MultiCyclone.



Note: The MultiCyclone is designed to filter sediment that is heavier than water, floating debris cannot be filtered out by centrifugal filtration.

Easy to install

MultiCyclone is easy to and fits to most existing pool filtration systems.

Reduce backwash frequency



MultiCyclone + Sand (granular) filter = Reduction in backwash frequency + Extends the life of the filter media.

The reduction in backwash frequency of a sand filter could result in saving 7000 litres of water per year for an average domestic swimming pool.

Reduce filter cartridge maintenance



MultiCyclone + Cartridge filter = Reduction in cleaning frequency + Extends the life of the filter cartridge.

Simple Maintenance

It only takes 15 litres of water to flush MultiCyclone. Whilst the water pump is running, simply open the sediment purge valve until the sediment has been flushed out.

Waterco's MultiCyclone is designed to work effectively with Waterco's extensive range of pumps and filters.



Laboratory tests

The MultiCyclone was field tested on an outdoor swimming pool and the contents of its sediment chamber were laboratory tested.

The laboratory test below revealed that the MultiCyclone was capable of trapping sediment between 10 to 100 microns.

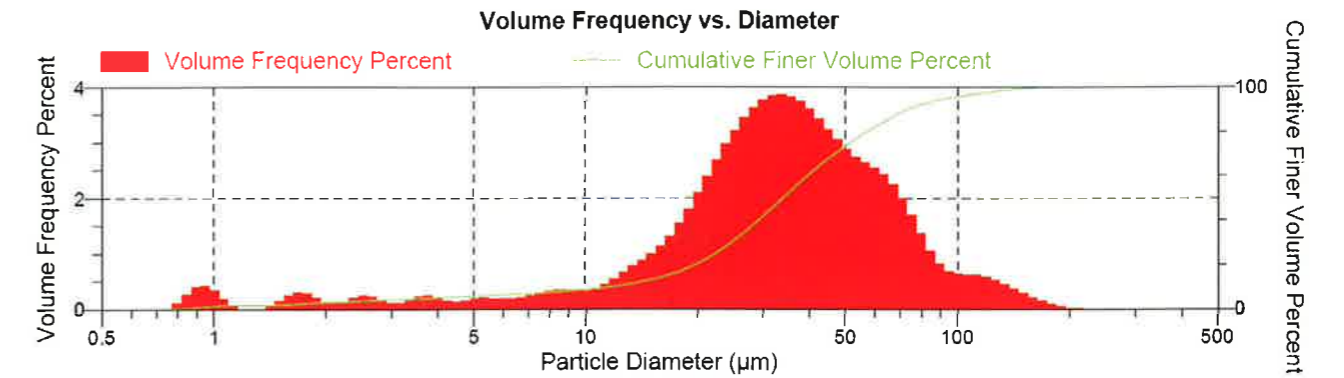

The filtration efficiency of the MultiCyclone was tested by feeding 5 to 80 micron dust particles through the MultiCyclone and analyzing the percentage dust particles trapped in the sediment chamber.

The laboratory test below revealed that the MultiCyclone was effective in filtering particles sized 40 to 80 microns.

Micron Rating	Particle Size 11.6 NTU Influent	Particle Size 10.2 NTU Effluent	Average % of Particles trapped
5.0 – 80.0	24141	16824	30.31%
5.0 – 20.0	23608	16561	29.85%
20.0 – 40.0	509.20	260.13	48.91%
40.0 – 60.0	22.000	2.861	86.97%
60.0 – 80.0	2.333	0.000	100.00%

DE powder was passed through the MultiCyclone to discover its effective flow rate.

At 50 lpm, the MultiCyclone was able to remove approximately 60% of DE powder and at 350 lpm; the MultiCyclone was able to remove 80% of DE powder.

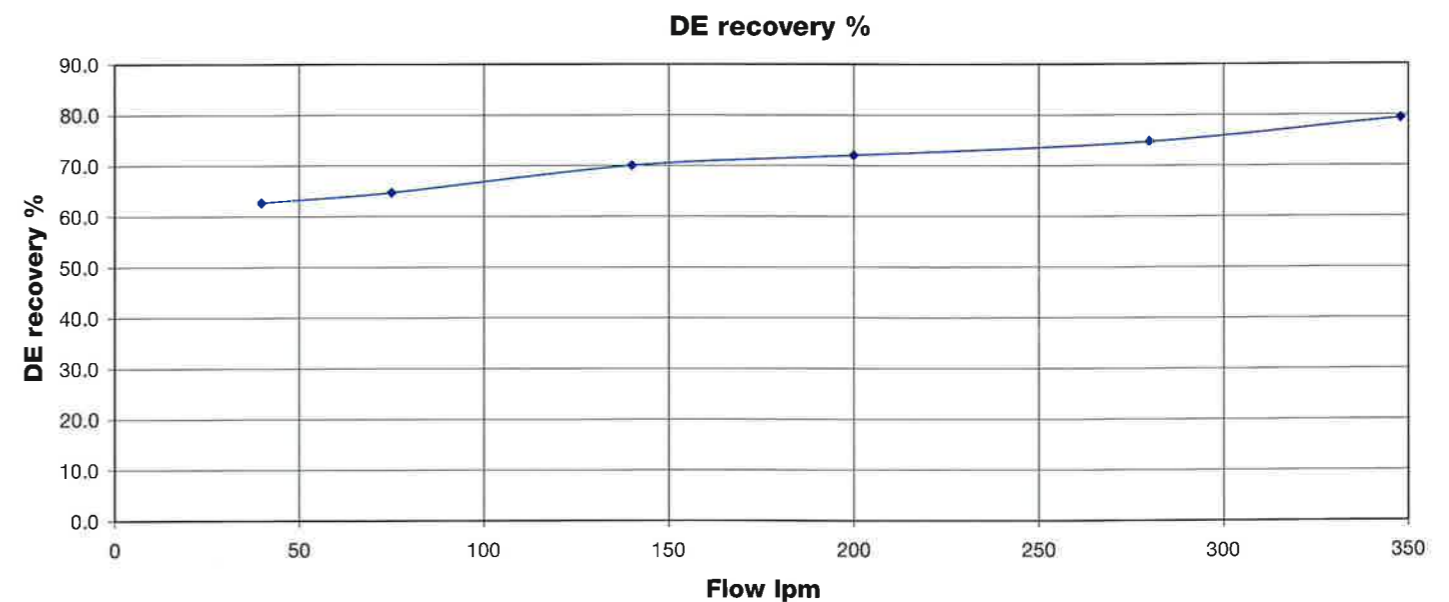

Head Loss Curves on MultiCyclone

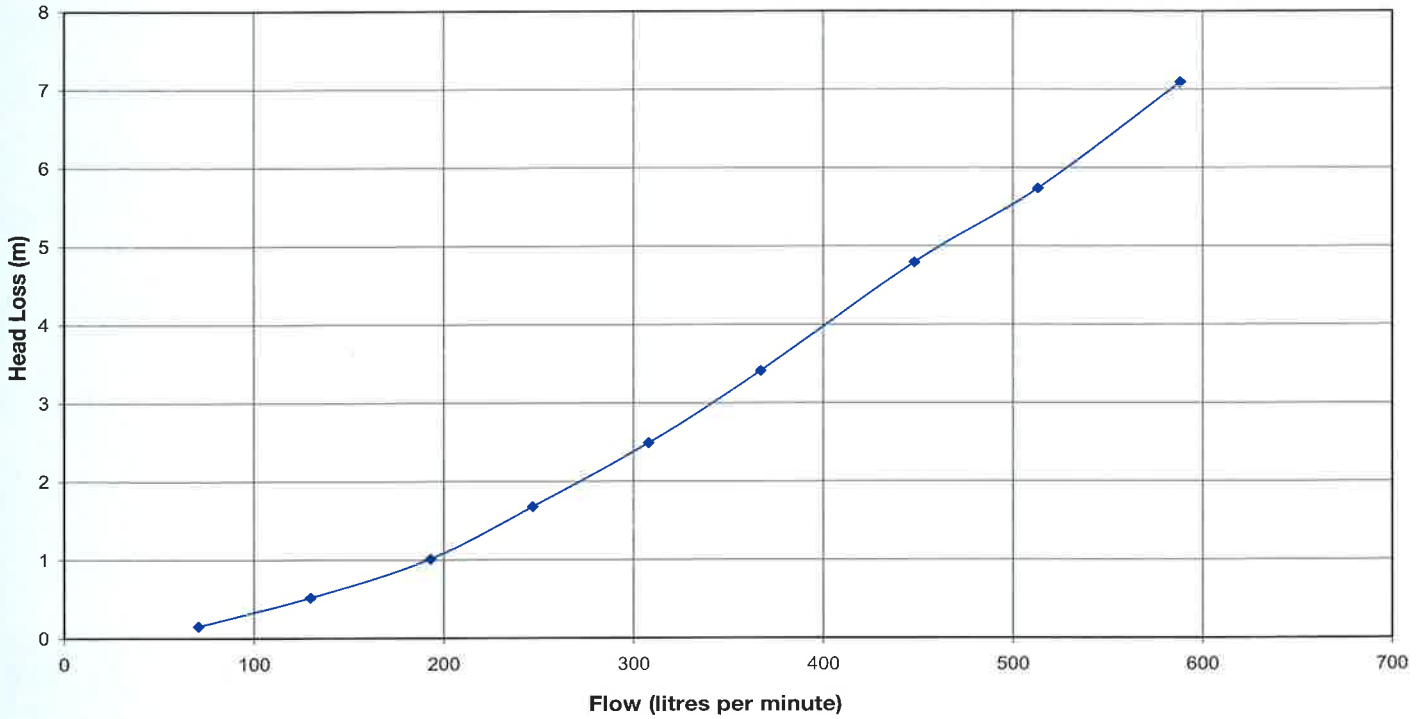

Minimum flow rate	Maximum flow rate
50 lpm	500 lpm

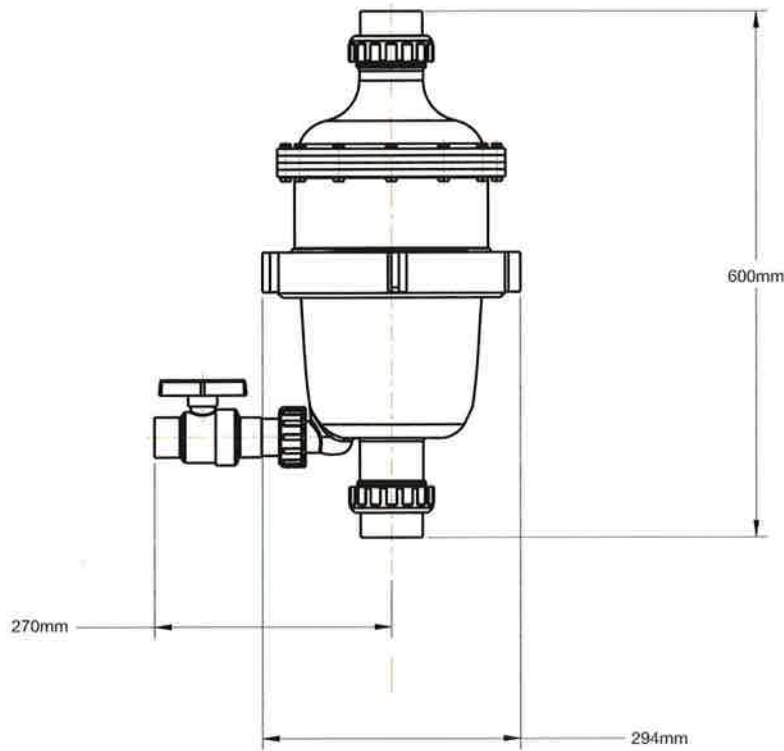

Warranty

MultiCyclone is covered by a 2 year warranty and 1 year warranty on labour. Commercial installations are covered by a 1 year warranty.

OFFICES - AUSTRALIA

NSW - Sydney (Head Office)
Tel: +61 2 9898 8600
QLD - Brisbane
Tel: +61 7 3299 9900
VIC/TAS - Melbourne
Tel: +61 3 9764 1211
WA - Perth
Tel: +61 8 9273 1900
SA/NT - Adelaide
Tel: +61 8 8244 6000
ACT Distribution
Tel: +61 2 6280 6476

OFFICES - OVERSEAS

Waterco (Europe) Limited
Radfield, Kent, UK
Tel: +44 (0) 1795 521 733
Waterco (USA) Inc
Augusta, USA
Tel: +1 706 793 7291
Waterco Canada
Quebec, Canada
Tel: +1 450 796 1421
Waterco (NZ) Limited
Auckland, New Zealand
Tel: +64 9 525 7570

Waterco (GZ) Limited
Guangzhou, China
Tel: +86 20 3222 2180

Waterco (Far East) Sdn Bhd
Selangor, Malaysia
Tel: +60 3 6145 6000

PT Waterco Indonesia
Jakarta, Indonesia
Tel: +62 21 4585 1481

DISTRIBUTED BY:

WATERCO
Water, the liquid of life

