

Power Master® POOL PUMPS



The Power Master® range is specifically designed to circulate swimming pool water for filtration and solar heating applications. They are ideal for in-floor & automatic cleaners. Also suitable for heating systems and aquaculture applications.

FEATURES & BENEFITS

Reliable

Constructed of strong corrosion and U.V. resistant materials for long and reliable working life.

Built-in check valve reduces reverse flow of water through pump protecting pump internals.

Extra heavy duty totally enclosed fan cooled motor protects against water, dust and dirt for long operating life.

Built-in thermal overload protects the motor against damage from over-heating.

Every unit is pressure and performance tested in factory ensuring quality and reliability.

Long Lasting

High performance Silicon Carbide mechanical seal, fitted as standard for long life in salt & fresh water.

Performance

Powerful high performance pumping delivers optimum flow rates for rapid pool water turnover.

Performance continued...

Computer-designed impeller and diffuser allow a free flow of water offering whisper quiet, efficient performance.

Convenient

Easy to remove, see through strainer lid for easy removal of leaves.

Drain plug enables pump casing to be drained for easy maintenance.

Extra large strainer basket allows long intervals between cleaning & rapid priming.

A.B.S. quick connect couplings makes installation simple.

Three phase model available for commercial pools and aquaculture applications.

2m power lead with 10amp Australian three pin plug fitted to all single phase models.

DEPEND ON
DAVEY

WATER PRODUCTS

DESIGNED & MADE IN AUSTRALIA 3yr FULL GUARANTEE

Power Master[®] POOL PUMPS

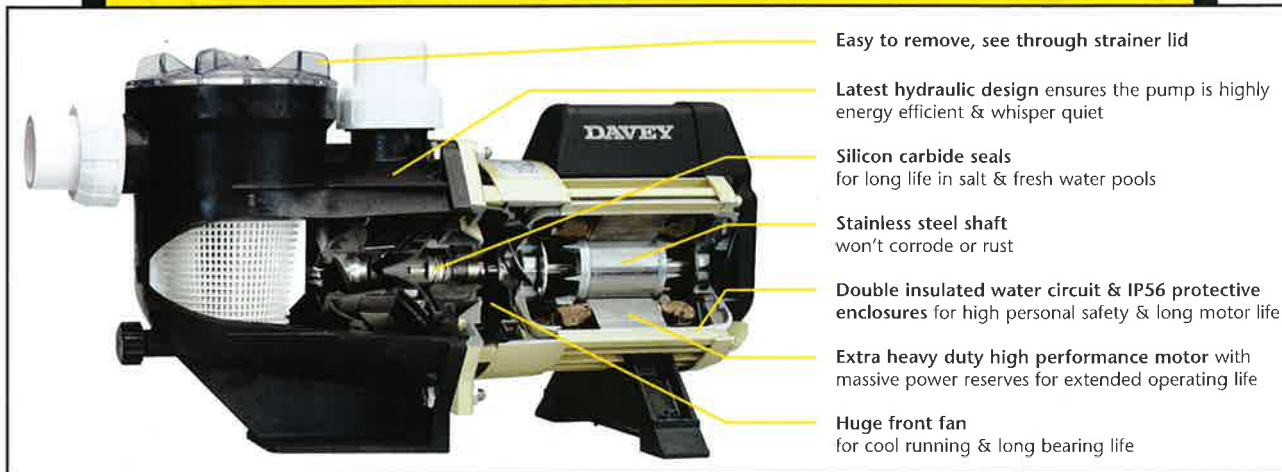

- Easy to remove, see through strainer lid
- Latest hydraulic design ensures the pump is highly energy efficient & whisper quiet
- Silicon carbide seals for long life in salt & fresh water pools
- Stainless steel shaft won't corrode or rust
- Double insulated water circuit & IP56 protective enclosures for high personal safety & long motor life
- Extra heavy duty high performance motor with massive power reserves for extended operating life
- Huge front fan for cool running & long bearing life

ELECTRICAL DATA

Model No.	PM200	PM250	PM350	PM450	PM450/3
Voltage (V)	220-250				380-415
Phase	1				3
Supply Frequency	50Hz				
Start Current (A)	27	27	27	40	24
Run Current (A)	5.8	6.5	7.7	10.0	3.6
Motor Input Power (W)	1200	1360	1675	2300	2040
Motor Output Power (W)	900	1000	1200	1775	1750
RPM	2850				
Enclosure Class (IP)	56				
Insulation Class	F				
Approval No.	Q97235				

OPERATING LIMITS

Water Temperature	Max 50°C
Ambient Temperature	Max 55°C
dBa @ 1 metre	64 - (PM200/250/350) 65 - (PM450/3)

MODEL NUMBER IDENTIFICATION

PM	250
PM = Power Master [®]	250 = 250lpm @ 12m per head.

MODEL	A	B	C	D	E	Mounting Holes Dia. (mm)	Inlet P.V.C. (mm)	Outlet P.V.C. (mm)	Net Weight (kg)
PM200	615	330	250	305	246	10	40/50	40/50	15.9
PM250	615	330	250	305	246	10	40/50	40/50	15.9
PM350	615	330	250	305	246	10	40&50	40&50	16.0
PM450/3	635	330	250	305	246	10	50	50	18.6

All dimensions in mm unless otherwise stated.

HYDRAULIC PERFORMANCE

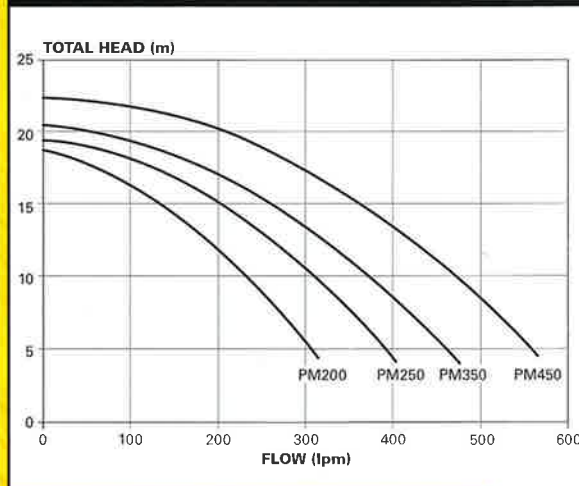

DIMENSIONS

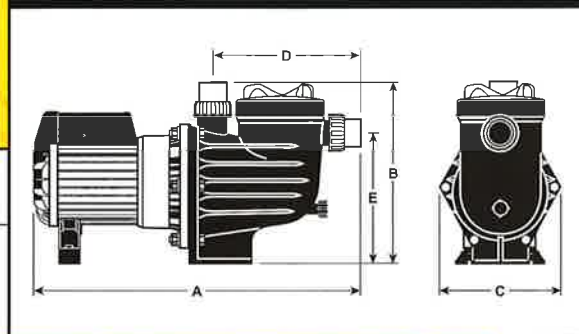

DEPEND ON
DAVEY

WATER PRODUCTS



Visit Davey on-line for further information
davey.com.au

All details in this leaflet are accurate at time of printing. This literature is not a complete guide to product usage. Further information is available from your Davey dealer, Davey Customer Service Centre and from the relevant product Installation & Operating Instructions. This datasheet must be read in conjunction with the relevant product Installation & Operating Instructions and all applicable statutory requirements. Product specifications may change without notice. © Davey and Silensor are registered trademarks of Davey Water Products Pty Ltd. © Davey Water Products Pty Ltd 2002.

Davey Water Products Pty Ltd

Member of the GUD Group
ABN 18 066 327 517
Head Office and Manufacturing
6 Lakeview Drive, Scoresby, Australia 3179
Ph: +61 3 9730 9222
Fax: +61 3 9753 4100
Website: davey.com.au
Customer Service Centre
Ph: 1300 2 DAVEY (1300 232 839)
Fax: 1300 304 850
E-mail: sales@davey.com.au
Interstate Offices
Sydney • Brisbane • Adelaide • Perth • Townsville

International

6 Lakeview Drive,
Scoresby, Australia 3179
Ph: +61 3 9730 9121
E-mail: export@davey.com.au

New Zealand

7 Rockridge Avenue,
Penrose, Auckland 1330
Ph: +64 9 570 9135
Website: daveynz.co.nz
E-mail: sales@daveynz.co.nz

Germany

Kantstrasse 53,
04275 Leipzig
Ph: +49 341 301 0412
E-mail: akrenz@daveyeurope.com

USA - Davey Pumps Inc.

1005 N. Commons Drive,
Aurora, Illinois 60504
Ph: +1 630 898 6976
Website: daveyusa.com
E-mail: sales@daveyusa.com